

Top View

Vinyl Covered
Lightweight
High-strength
Concrete

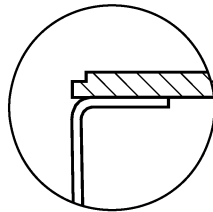

TecTrim

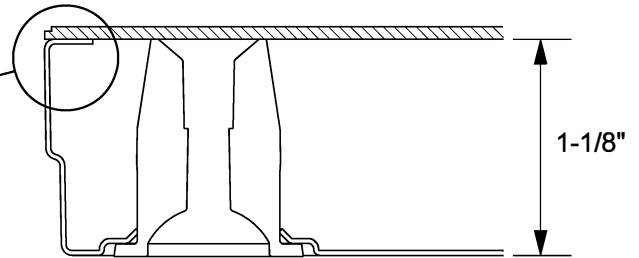

1-1/8"

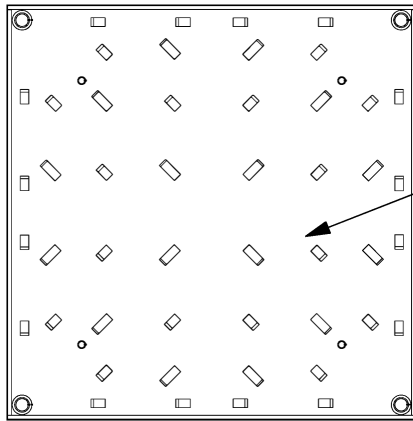

Bottom View

Galvanized
Steel

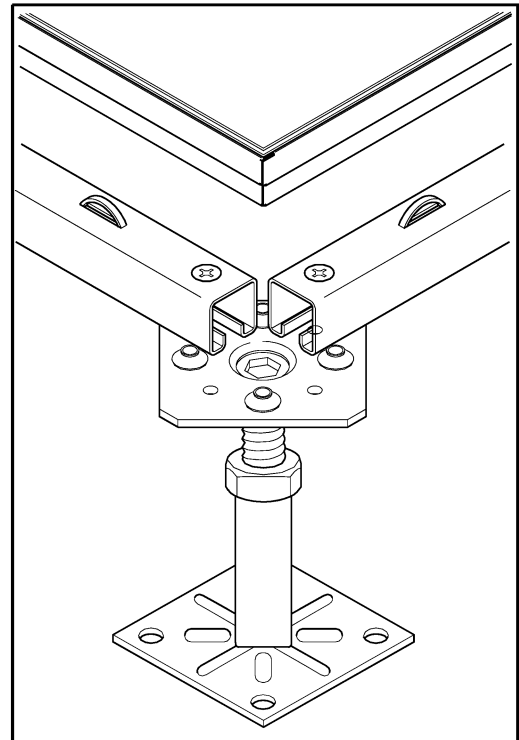

Typical Vinyl Covered TecCrete
Stringer Supported configuration

Specifications:

Lightweight High-strength Concrete
 Hot-dipped Galvanized Steel
 Panel Size (Nominal): 24" x 24" 1-1/8"
 Finished Floor Height: 3" to 91"
 Overall Pedestal Adjustment: ±1" height (FFH>6")
 Tolerance: Nominal panel size ±0.015"; flatness & squareness within ±0.015"

Tec-Crete performance ratings

Rolling loads are expressed in pounds per caster; all other data is stated in maximum pounds of load and inches of deflection or permanent set.
 Total System Weight = 11.9 lbs./sq. ft. (up to 13.5" FFH).

Key to performance ratings

Haworth has tested its flooring system to "Recommended Test Procedures for Access Flooring"--Ceiling and Interior Systems Construction Association (CISCA). Uniform and Impact tests have also been conducted. Stringers are edge supporting. Testing reflects weakest point, top surface deflection in accordance with CISCA.

- 1.) Uniform load data is based on maximum deflection of 0.040". Typical slabs under access floors have uniform load capacities less than the rating of lowest uniform load capacity of any TecCrete series floor.
- 2.) Rolling tests used in the CISCA test procedures are performed as follows: 10 passes with a 3" x 1-13/16" caster; 10,000 passes with a 6" x 2" caster. Worst-case permanent set (inches) is shown for each system.
- 3.) Impact tests are based on 36" drops onto a 1 inch square indenter without ultimate failure of the system.

Rolling ²		Impact ³	Concentrated	Uniform ¹
10 passes	10,000 Passes		PSI	PSF
1500 ≤ .040	1250 < .040	150	1500 < .10	700 < .040