

Corner-Lock Application

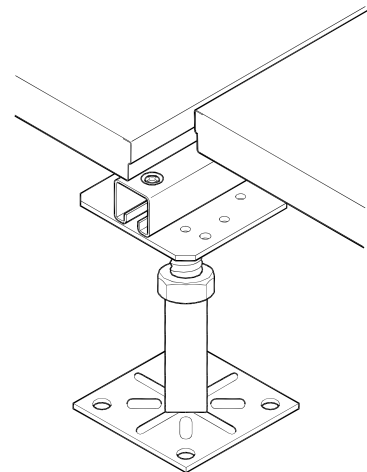

Universal Perimeter Application

Specifications:

- * Formed from high-strength low alloy steel
- * Tested to CISCA Access Floor Section 4 Stringer Load Test, passes 500lb point load with less than a .010" permanent set